

# 300 GALLON SEEP TANK

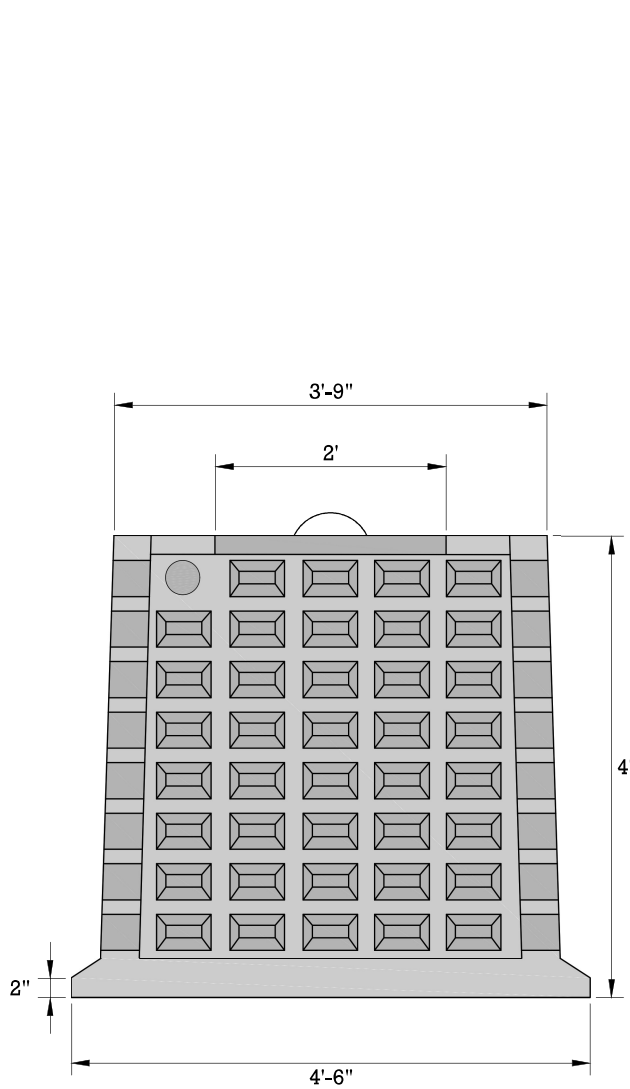

**FRONT VIEW**

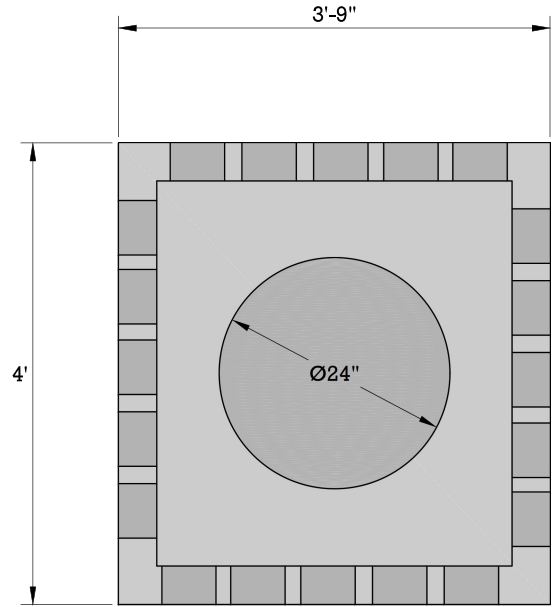

**TOP VIEW**

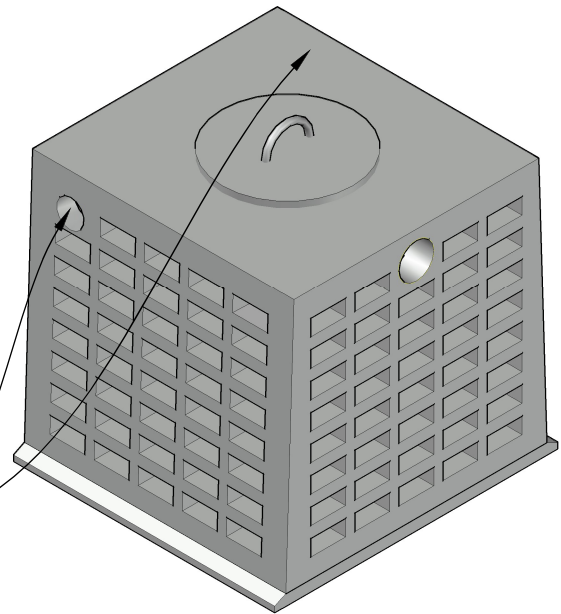

**ISOMETRIC VIEW**

**4" POLY SEALS (INLET)**

			WEIGHT (LBS)	SPECIFICATIONS
				<b>Concrete: 4000PSI @ 28 days</b>
				<b>Reinforcement:</b> Bar ASTM A615 GR60 WWR ASTM A185/A497 GR65
				<b>Structure is designed to meet HS 20-44 loading requirements</b>
				<b>Frame and Grates Available; Heavy Duty &amp; Bicycle Safe</b>