

500 Gallon Septic Tank

**SPECIFICATIONS:**

**CONCRETE:** 5,000 Psi @ 28 Days  
**Air Entrainment:** 5% - 9% Target 7%  
**Steel Reinforcement:** Grade 60 ksi  
 ASTM A615/A615M  
 ASTM A1064/A1064M – 16B  
**Design Load:** 300 psf  
 AASHTO Method of Design  
 Soil Pressure of 40 pcf  
**Water Table:** TYP. 3' Below Finished Grade  
**Earthen Fill:** up to 12"  
  
**Weight:**  
**Monolithic Tank:** 4,988lbs  
**Top Slab:** 825lbs  
**Total:** 5,813lbs

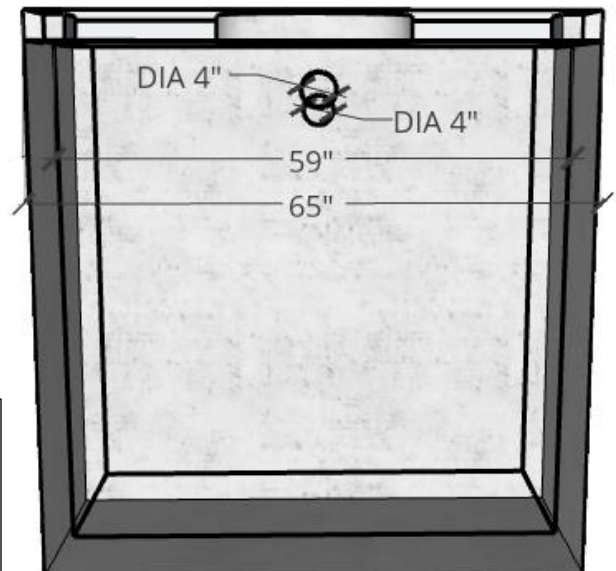
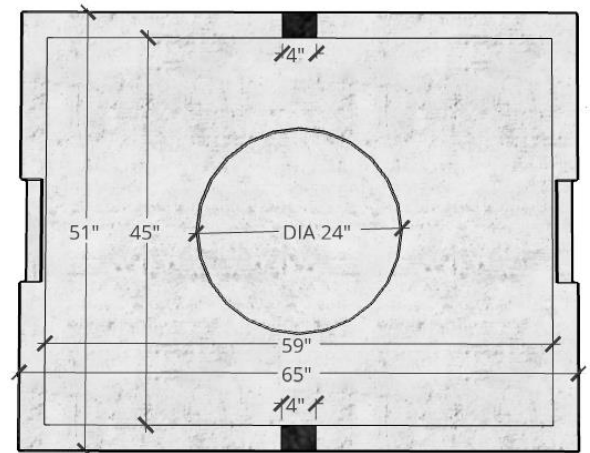
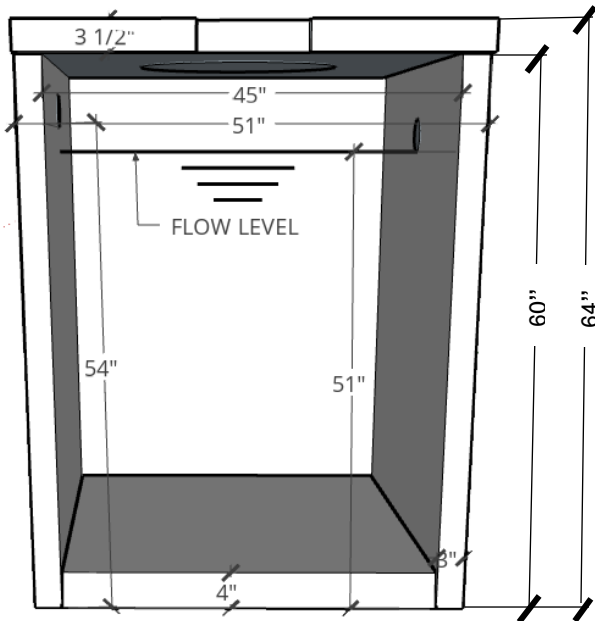

- Top Slab is sealed with 1" Concrete Sealant Mastic
- 6" & 12" Reinforced riser tubes are available
- Additional Inlets and Outlets can be placed upon request